

REVISIONS			
REV.	DATE	DESCRIPTION	DATE

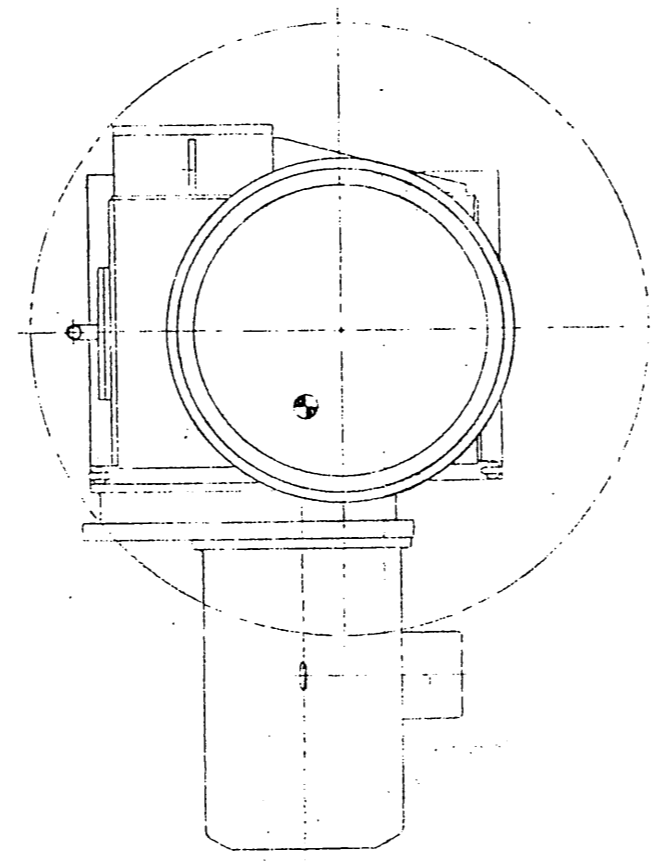

SPECIFICATIONS:
 1) LINE PULL: 5000 LBS AT 60 FPM
 10000 LBS AT 30 FPM
 2) BARREL DIAMETER: 18 INCHES
 3) ELECTRIC MOTOR: 15 HP, 440 V, 60 HZ,
 1800/900 SYNC. RPM

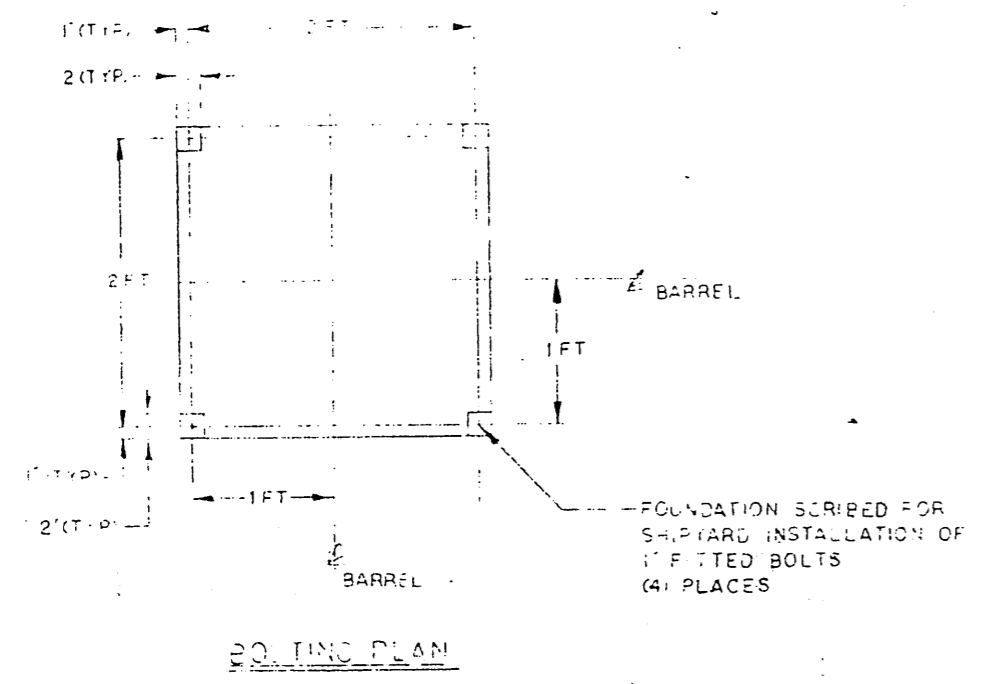
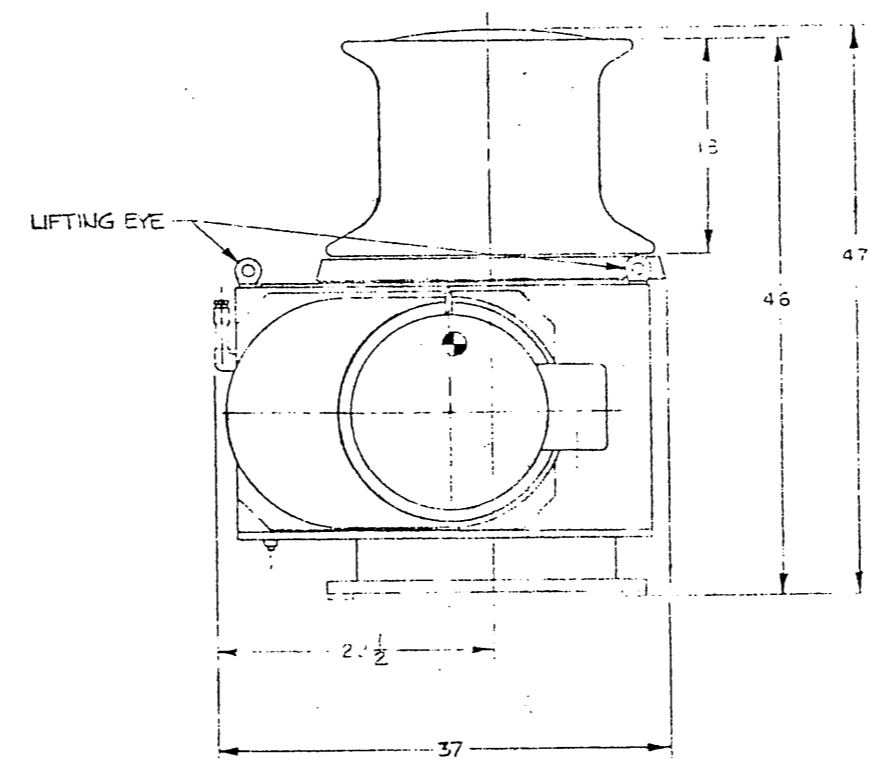
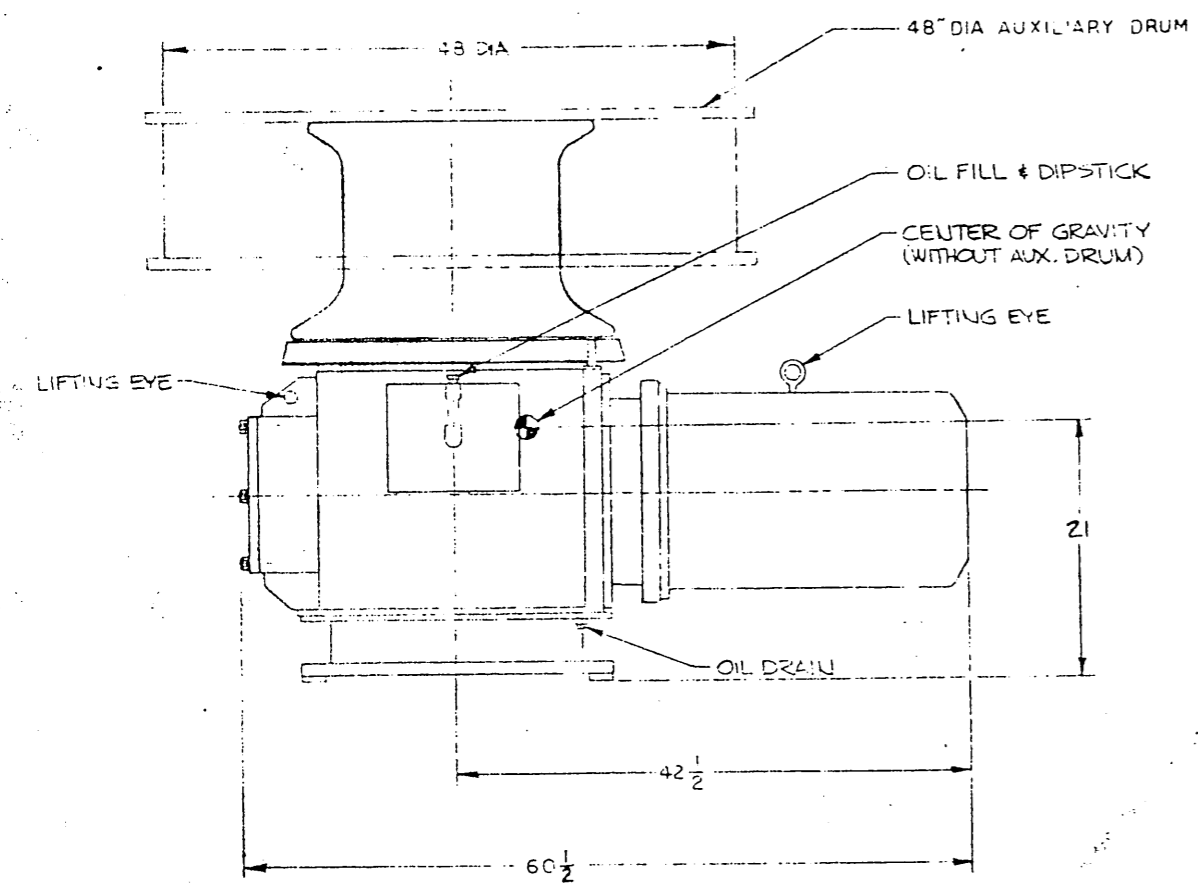

ITEM FIND NO.	REQD QTY	CODE IDENT NO.	DRAWING NUMBER	PART OR IDENTIFYING NUMBER	NOMENCLATURE OR DESCRIPTION	MATERIAL	EQUIVALENT GOVT OR MIL SPECIFICATION
UNLESS OTHERWISE SPECIFIED DIMENSIONS ARE IN INCHES TOLERANCES ON					CONTRACT OR PROJECT NO. 55003-05		
FRACTIONS =					DRAWN = <i>Handwritten</i> 4/1/73		
DECIMALS					CHECK = <i>Handwritten</i> 4-3-73		
X = .1					ENGR = <i>Handwritten</i> 4/17/73		
XX = .03					SIZE CODE IDENT NO. DRAWING NUMBER		
XXX = .010					F. 25511 14592		
NEXT ASSY USED ON (1st PL)					APPROVED		
MODEL NO.					SURFACE FINISH MICROINCHES RHR		
APPLICATION					DO NOT SCALE THIS DRAWING		
					SCALE 1/8" = 1" WEIGHT 4500 LBS INCL SHEET		